

HG ROV-Surface Powered User Manual

CHARPIE



CHARPIE INTELLIGENCE TECHNOLOGY, CO., LTD

Using this manual

Legends



Note



Attention

Before Usage

Make sure all of the parts listed in the In the Box are included in the case. Read the ENTIRE User Manual carefully to become familiar with the features of this product before operating.

Thank you for your purchase, we hope you enjoy using it!

Contents

1. Introduction	1
2. Hardware Setup	3
2.1 In the Box	3
2.2 System Connection	4
2.3 Surface Connection	5
3. Software	6
3.1 Software Installation	6
3.2 User Interface	9
3.3 Joystick Controller Calibration	10
3.4 Sensor Calibration	11
4. Functionality Confirmation	12
4.1 Desktop Test	12
4.2 Underwater Test	13
5. Recovery and Cleaning	14
6. FAQ	15
7. Service and Tutorial	17
7.1 After-sale Service	17
7.2 Online Tutorial	17
8. Upgrades and Accessories	18

1. Introduction

HG series products are currently serving in over 40 countries across all industries. Each day, our ROV products find and retrieve objects in the water, inspect infrastructure both inland and offshore, and keep divers safe from hazardous conditions.

Applications



Water Environment



Underwater Infrastructures



Hydro-Dams

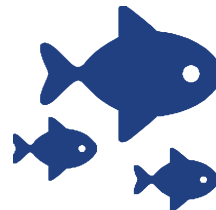

Aquaculture



Maritime Salvage



Marine Constructions



Ports & Wharf



Law Enforcement

The full HG series product is a surface powered ROV (Remotely Operated Vehicle). It is a compact designed, one-man portable and high-performance underwater ROV standing up to 4 knots of water current with unlimited underwater operation hours.

The ROV is highly maneuverable with 6-8 thrusters and designed to be reliable and extendable with multiple sensors. We offer Autonomous/ Manual modes for efficient operations.

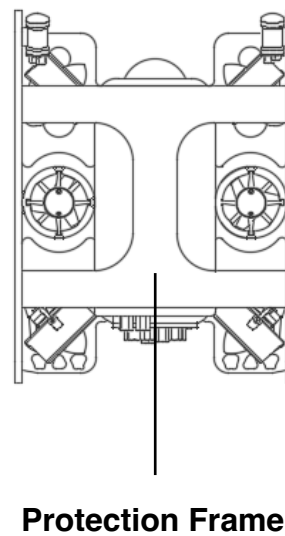
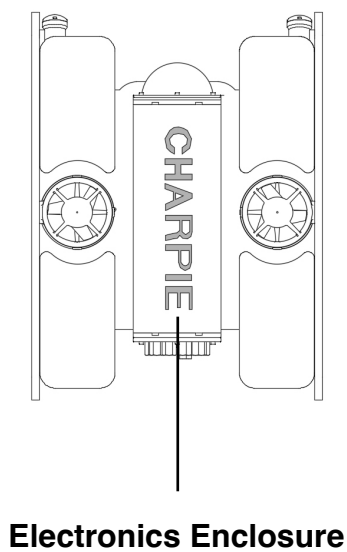
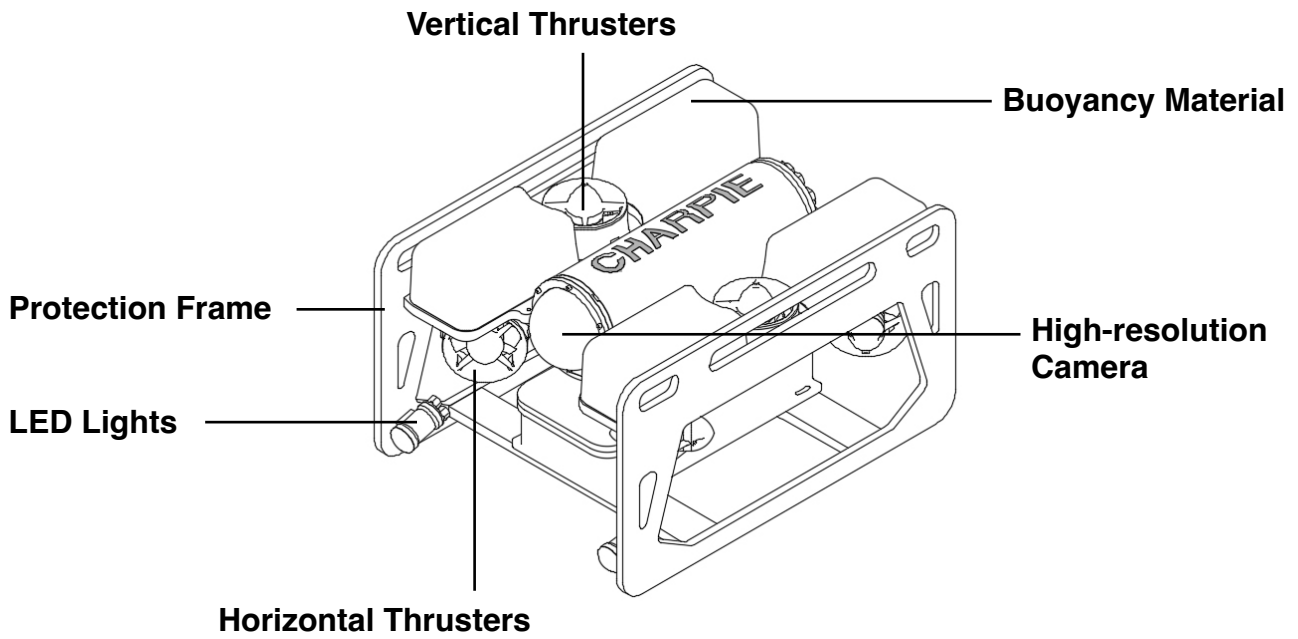

2. Hardware

2.1 In the Box

1. HG Series ROV x 1
2. Umbilical Cable with Winch x 1
3. Connecting Cable x 3
4. Laptop x 1 (Sold separately)
5. Surface Hub x 1
6. Joystick Controller x 1
7. Spare Ballast x 2

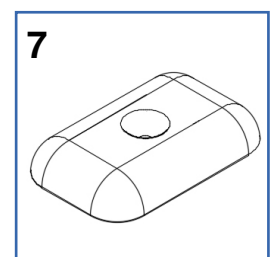
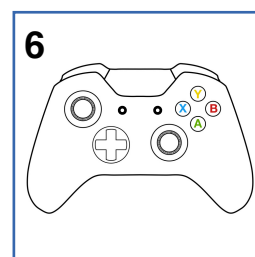
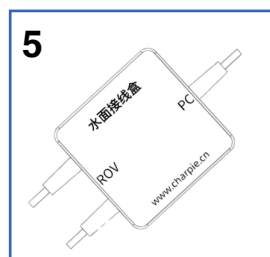
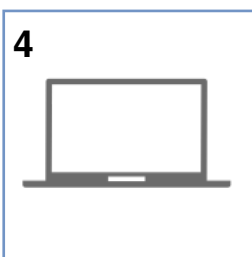
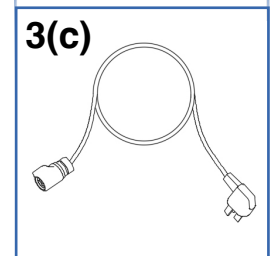
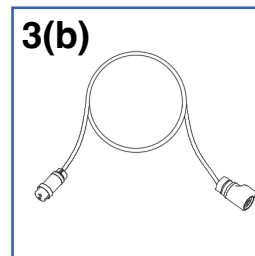
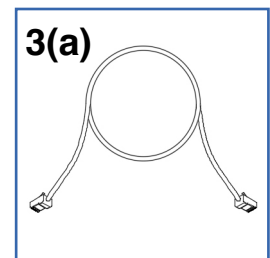
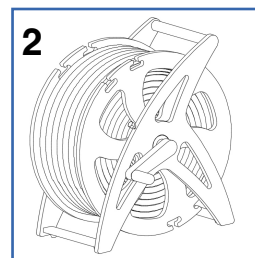
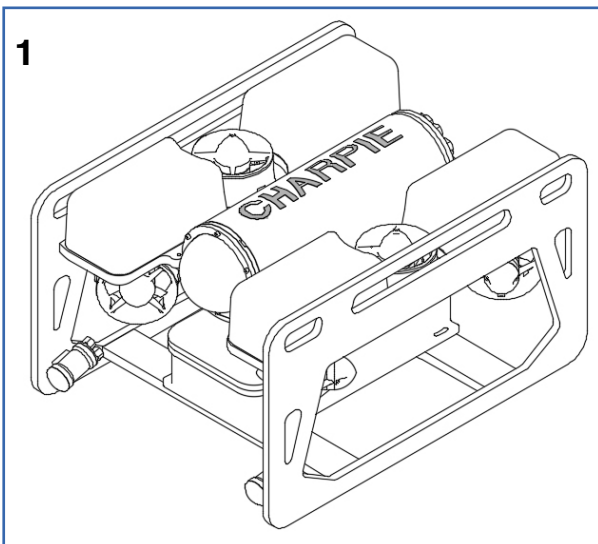

2.2 System Connection

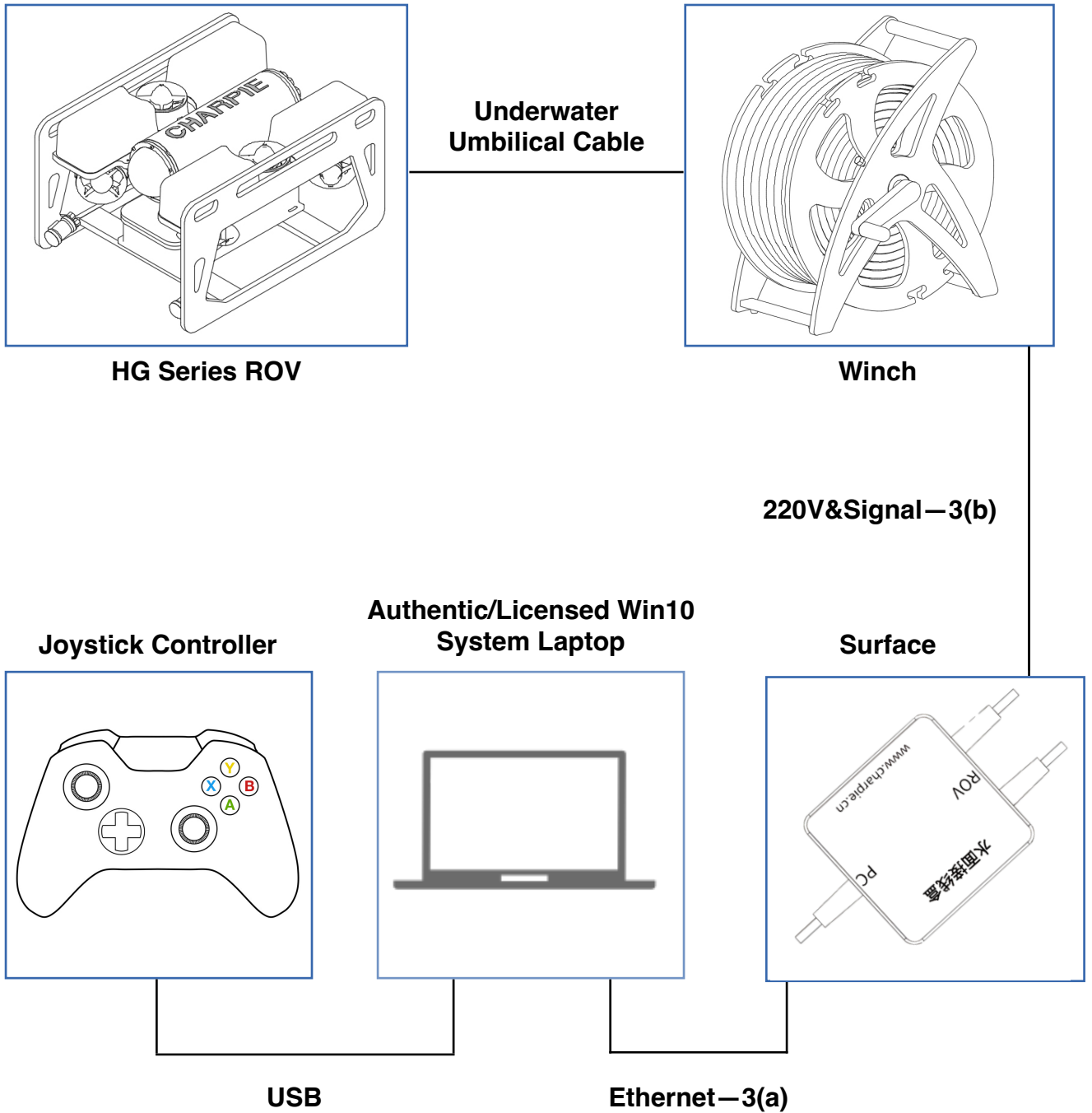

3. Software

3.1 Software Installation

 • Skip this step if you have purchased a pre-configured laptop.

1. Download and Unzip the 'Charpie GC' file, run the 'Charpie GC.exe'.



2. In the pop-up window choose both 'Private networks' and 'Public networks' then click 'Allow access', wait until the software shows up.

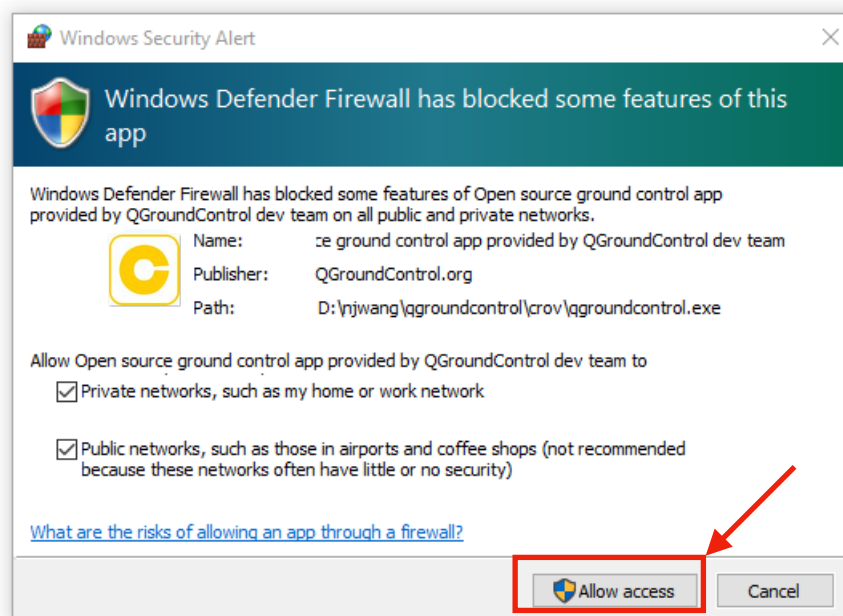

3. Close the Charpie GC software.

4. Copy the '***.ini' file to the 'C:\Users\your name\AppData\Roaming\QGroundControl.org\' folder, and choose 'Replace'.

- 'your name' needs to be modified according to your personal username.

5. Plug the line to the Surface Connector, right-click the network, open 'Network and internet settings', click 'Change adapter options', right-click 'Ethernet', select 'Properties', double-click 'Internet protocol version 4 (TCP / IPv4)', set the IP address to 192.168.2.1.

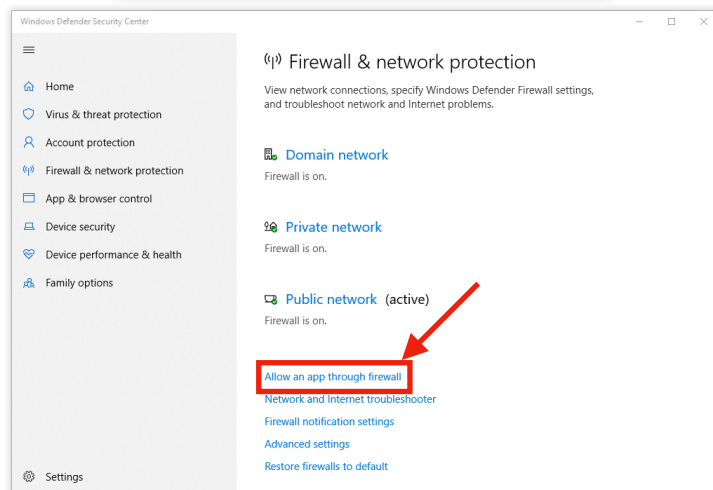
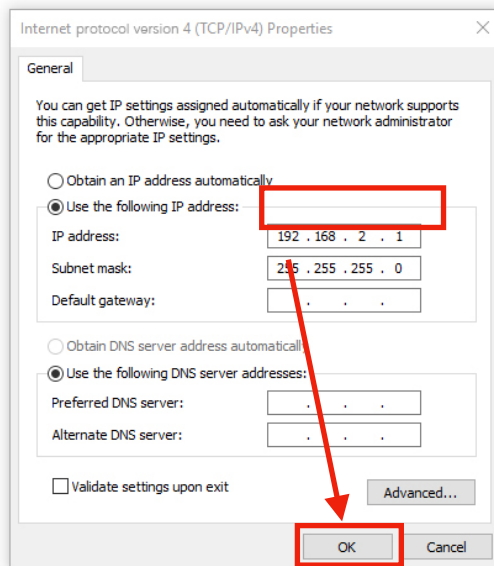

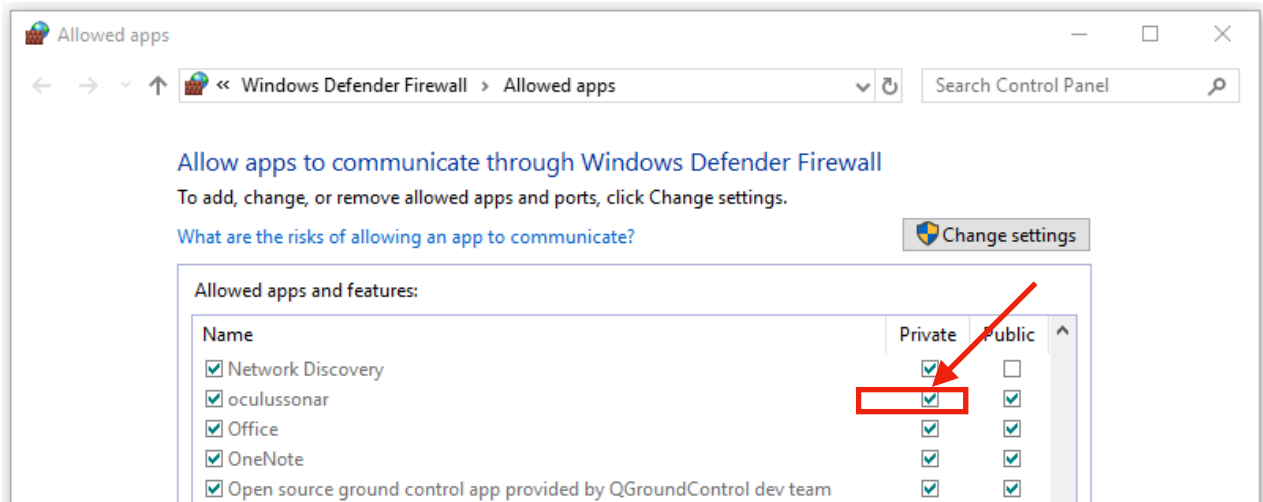

3.2 User Interface

The screenshot shows the CHARPIE user interface. At the top, there are labels for 'Return to Home Page', 'Control Mode (Manual / Depth Hold / Stabilize)', 'Real-time Voltage', 'Arm/Disarm', 'ROV Settings', and 'Software Settings'. The interface includes a status bar with 'Manual' mode, '24.30v' voltage, and 'Disarmed' status. A data bar displays 'Depth: 0.1m Pilot Gain: 10% Current: 2.00A Water Temp: 16°C Cabin Temp: 28°C Time: 11:21:33 Date: 10/03/2020'. The main area is a video feed of underwater. A 'Record Video Stream' button is visible. At the bottom, there are 'Attitude' and 'Compass' gauges. The compass shows a heading of 286 degrees.

3.3 Joystick Controller Calibration

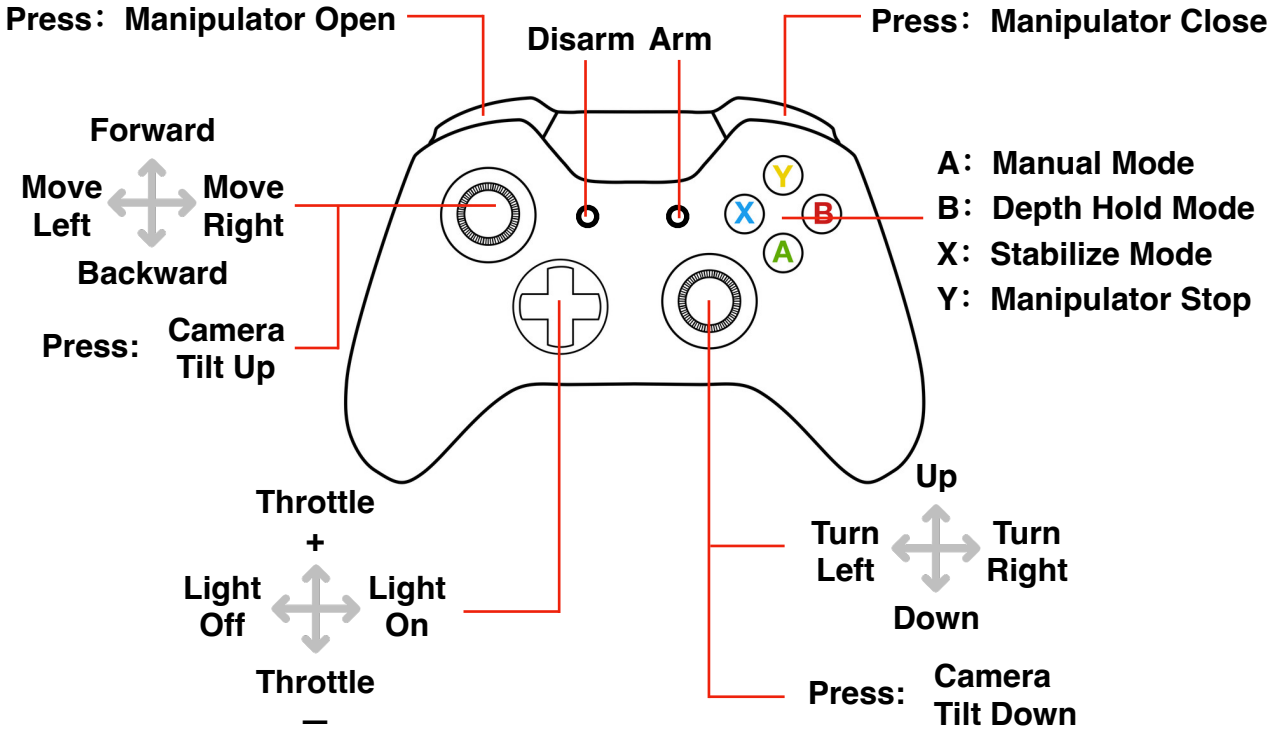

• Skip this step if you have purchased a pre-configured laptop.

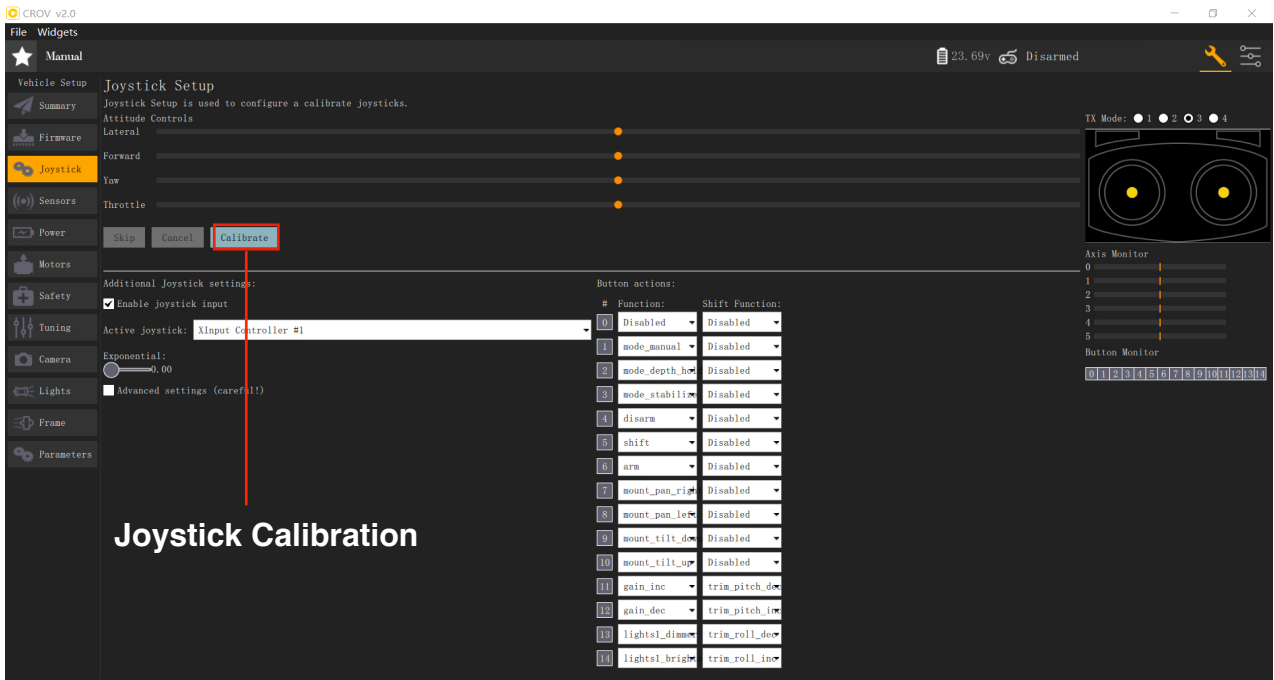

3.4 Sensor Calibration

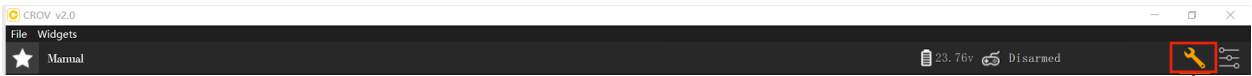

Click to enter the sensor calibration page.

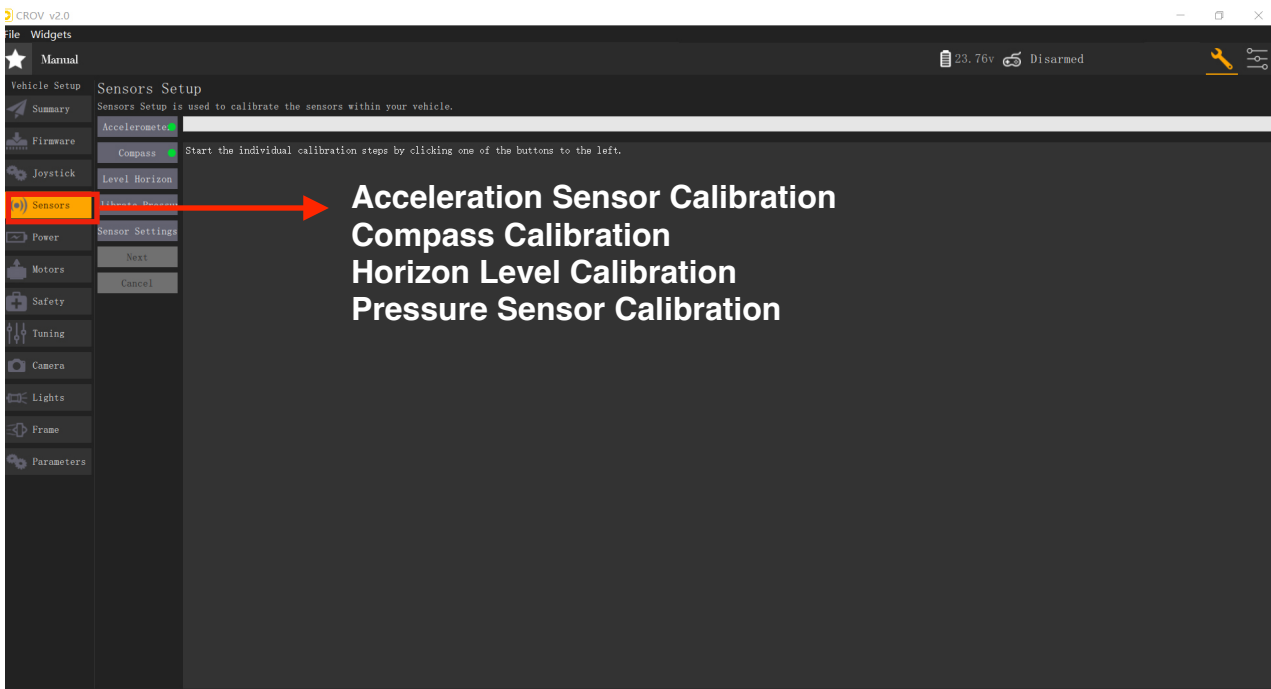

-
- ⚠ • DO NOT change other settings if is unnecessary.
 - If you have any question please contact our technical staff.
-

4. Functionality Confirmation

4.1 Desktop Test



- **DO NOT** let the thrusters run consecutively for more than 5s.
 - **DO NOT** let the LED lights turned on consecutively for more than 10s.
 - **ONLY** use Manual mode during desktop tests, or motors will be damaged.
-

1. Open screen recording software, choose full screen recording.
2. Open the CROV software wait until the connection between PC & ROV is through and stable.
3. Video display is fluent.
4. Thrusters rotate accordingly with joystick controller (forward/backward, up/down, etc.).
5. The camera gimbal returns to neutral after startup.
6. All lights can be turned on and adjust brightness correctly.
7. The air vent has been tightened.
8. All screws are tightened.
9. Cable outer jacket is intact.

4.2 Underwater Test

- ⚠ • **Leaks may happen if vent is not wholly tightened.**
 - **All loose screws MUST be tightened, ROV may be lost otherwise.**
 - **Operating with broken umbilical cable is FORBIDDEN, leaks or even loss of ROV may happen.**
 - **DO NOT use ROV when water speed is more than 2 m/s.**
 - **The rated current is 40A. More than rating it might damage the ROV.**
 - **Disarm the ROV and retrieve it immediately if required.**
-

1. ROV is neutrally buoyant in fresh water and slightly positive in salty water.
2. Video stream is fluent with low latency. No mosaic on image.
3. Try up/down, forward/backward with the joystick controller. Check for smooth movement.
4. Test for speed up/slow down. Check for correct pilot gain reading.
5. Test Depth Hold/Stabilize mode.
6. Take a note on the current heading for destination.

5. Maintenance

5.1 Recovery and Cleaning

1. Switch to Manual mode.
2. Turn off the LED lights and retrieve the ROV back to surface.
3. Open the battery cabin and disconnect the battery with dry hands.
4. Tidy up the thrusters if any debris stuck inside.
5. Rinse the ROV with fresh running water, including the thrusters and tether. Dry up the ROV with clean cloth.
6. Disconnect the cable from the winch and surface control unit.
7. Straighten up the tether on the reel.
8. Keep the ROV in dry and safe storage.
9. Apply silicon grease on O-rings for easier opening next time and better sealing.

6. FAQ

1. 'Waiting for connection' message when the ROV is powered up

Generally it takes several minutes or longer for the connection, so please be patient and wait.

If the connection still failed please check the following items:

- ① The umbilical cable is connected firm and tightened.
- ② The local IP address and firewall settlings on your laptop is correct.

2. The thrusters are running out of control when ROV is powered up in the air for desktop test

- ① Change to 'Manual' mode if it is on 'Depth Hold' or 'Stabilize' mode.
- ② Calibrate the joystick controller.
- ③ If all the above attempts tried but still unfixed, disarm the ROV and close the CROV software, contact our tech supporting staff.

3. ROV is not walking straight when asked to

- ① Check if all 6 thrusters are working, especially the horizontal ones. If any of them not working, please power off the ROV and check if any debris or trash stuck inside the motor.
- ② Check the directions of all 4 horizontal thrusters when going forward. If any of them is running the other direction, change the motor direction setting under the guidance of our technical staff.

4. Abnormal depth reading on the UI

Re-calibrate the depth sensor in air.

5. Only video streams without parameter readings

Double click on the video to show the readings.

6. Over-Current

This normally happens in strong water currents, stalled motors or entangled tether. Unlock the control joystick immediately, close the CROV and retrieve the ROV back to the surface for a closer check.

7. Interrupting videos or Mosaic image

Most likely caused by entangled tether or over turnings of the tether. Straighten up the tether as much as possible for better video stream.

7. Service and Tutorial

7.1 After-sale Service

1. Free remote video tutorial session within 1 month since purchased.
2. Maintenance services free of labor costs within one year since purchased.
3. Free annual ROV diagnosis.
4. Send you description with videos & images to support@charpie.cn if anything further.
5. Call for emergencies: +86-21-5881-0772.

Shanghai office hours: Mon - Fri 8: 00-20: 00 (UTC: +8).

-
- ⚠ • **Machine failure caused by improper operations, unauthorised modification, and adverse application environment is NOT covered by the Warranty.**
-

7.2 Online Tutorial

1. YouTube channel with basic operation guides and daily maintenance tips.
2. Linkedin & Facebook updates on company news and new releases.

8. Upgrades and Accessories

For more accessory details, please visit our website www.buyrov.com or call during office hours: +86-21-5881-0772.

Tools	1. Manipulator
	2. Cleaning Brush
	3. Water Sampler
	4. Soil Sampler
	5. Dead Fish Net
	6. Cavitating Jet Cleaning Plate
	7. Underwater Marker & Locator
	8. Underwater Scissor
Structure Detection	1. Laser Scaler
	2. Thickness Gauge
Water Quality	1. PH
	2. Conductivity
	3. Turbidimeter
	4. Dissolved Oxygen
	5. Ammonia - Nitrogen
	6. Blue/Green Algae
Underwater Positioning	1. SBL / USBL
	2. Obstacle Avoidance Sonar
Sonar	1. Mechanical Scanning Sonar
	2. Multi-beam Forward Looking Sonar
	3. Side-scan Sonar
	4. 3D Bathymetry
	5. Fish Finder
	6. Sub-bottom Profiler
	7. Pipe-profiler

CHARPIE

28th Floor, 11 Century Avenue, Shanghai, China
+86-21-5881-0772
sales@charpierov.com

This User Manual is the property of Charpie Intelligent Technology Co., Ltd., and all rights of use are reserved. Contents are subject to change without prior notice. For the latest information, please contact our sales representatives.