

## Portable Underwater ROV (Battery Powered)

### Product Features

- Depth Rating of 300m with Aluminum housing
- 12kg, one person portable & deployable, easy retrieval
- Effortless operation with AI assisted driving
- 10+ accessories for more application scenarios;
- Long Distance System Options with 1000m | 2000m Armored Optical Cable

### Application Scenarios

- Search and Recovery (SAR)
- Infrastructure and Asset Inspection (dams, ports, tanks, etc)
- Aquaculture and Fisheries Monitoring
- Environmental and Marine Research
- Photogrammetry and 3D Mapping
- Public Safety and Emergency Response
- Education, Training, and Prototyping
- R&D Development and System Integration



### Basic Specs

Frame Parameters	Dimensions (mm)	457 * 339 * 255
	Weight (kg)	12.5
	Operating Depth(m)	300 (Standard) Other depths can be customized
Propulsion System	Thrusters	4 Horizontal + 2 Vertical
	Max Speed	4 knots
	Payload Capacity	10kg
	Control System	Main Processor: STM32F427,32-bit ARM Cortex-M4, NuttX RTOS. 3-Axis Gyroscope x2(MPU6000+L3GD20H) 3-Axis Accelerometer x2(MPU6000+LSM303D)
	Control Modes	Depth Hold   Stabilize   Manual
Camera & Lighting	Underwater Lights	Standard:2×1500 LM high-brightness LED lights, dimmable
	Camera	Gimbal Tilt:±50°, Sensor: Sony IMX219 Pixel:8MP, CCD Size: 1/4" Aperture(F):2.0, Focal Length:3.04 mm

		Field of View: 76°, Focus: Manual Video Stream:1080p30/720p60/640 * 480p90
Comm. & Power Supply	Endurance	Battery:2.5-8 hours
	Cable	Default: 100m (Reel purchased separately) Selection up to 2 km
Remote Control	Surface Unit	Standard
	Computer	User-provided (Windows 10+ or Ubuntu 22.04+)
	Software	Standard (Compatible with MAVLink protocol)
Optional Configurations		Manipulator/GoPro/Auxiliary Camera/ Imaging Sonar /Altimeter/ Pipe Sonar/ Underwater Positioning/ Water Quality Sensor/etc.
Customization		Communication Interfaces: USB/RS-485/ RS-232/ UART/ Ethernet, etc. Power:5VDC/12VDC/24VDC/220VAC ,etc.

## Main Dimensions

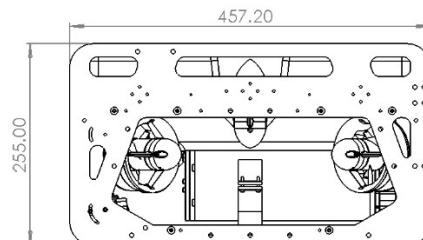
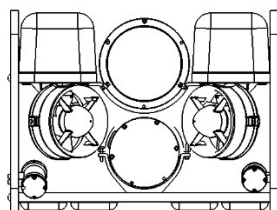
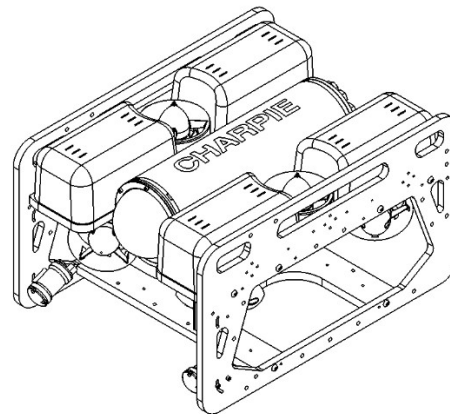
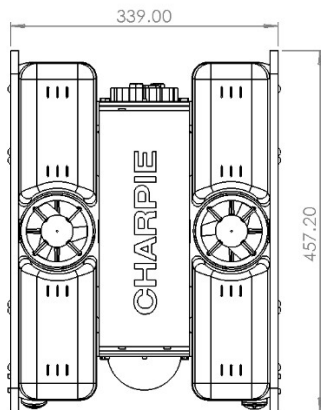

- Product specifications are subject to change without further notice. Please refer to our official website for latest information.