

HX ROV-Battery Powered User Manual

CHARPIE



CHARPIE INTELLIGENCE TECHNOLOGY, CO., LTD

Using this manual

Legends



Note



Attention

Before Usage

Make sure all of the parts listed in the In the Box are included in the case. Read the ENTIRE User Manual carefully to become familiar with the features of this product before operating.

Thank you for your purchase, we hope you enjoy using it!

Contents

1. Introduction	1
2. Hardware Setup	3
2.1 In the Box	3
2.2 System Connection	4
2.3 Battery Installation	5
2.4 Battery Charge	7
2.4.1 Charger Introduction	7
2.4.2 Connection	8
2.4.3 Charge Interface	8
3. Software	9
3.1 Software Installation	9
3.2 User Interface	12
3.3 Joystick Controller Calibration	13
3.4 Sensor Calibration	14
4. Functionality Confirmation	15
4.1 Desktop Test	15
4.2 Underwater Test	16
5. Maintenance	17
5.1 Recovery and Cleaning	17
5.2 Battery Attention	18
6. FAQ	19
7. Service and Tutorial	21
7.1 After-sale Service	21
7.2 Online Tutorial	21
8. Upgrades and Accessories	22

1. Introduction

HX series products are currently serving in over 40 countries across all industries. Each day, our ROV products find and retrieve objects in the water, inspect infrastructure both inland and offshore, and keep divers safe from hazardous conditions.

Applications



Water Environment



Underwater Infrastructures



Hydro-Dams

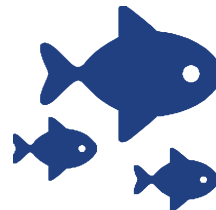

Aquaculture



Maritime Salvage



Marine Constructions



Ports & Wharf



Law Enforcement

The full HX series product base on a Li-ion battery powered ROV (Remotely Operated Vehicle), a compact designed, one-man portable and high-performance underwater ROV standing up to 4 knots of water current. The ROV is highly maneuverable with 6-8 thrusters and designed to be reliable and extendable with multiple sensors. We offer Autonomous/ Manual modes for efficient operations.

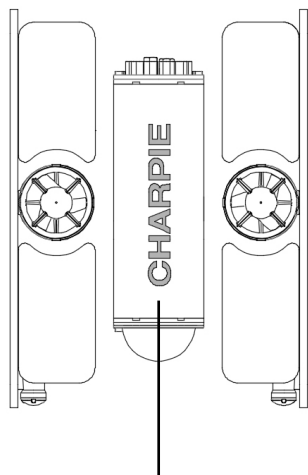
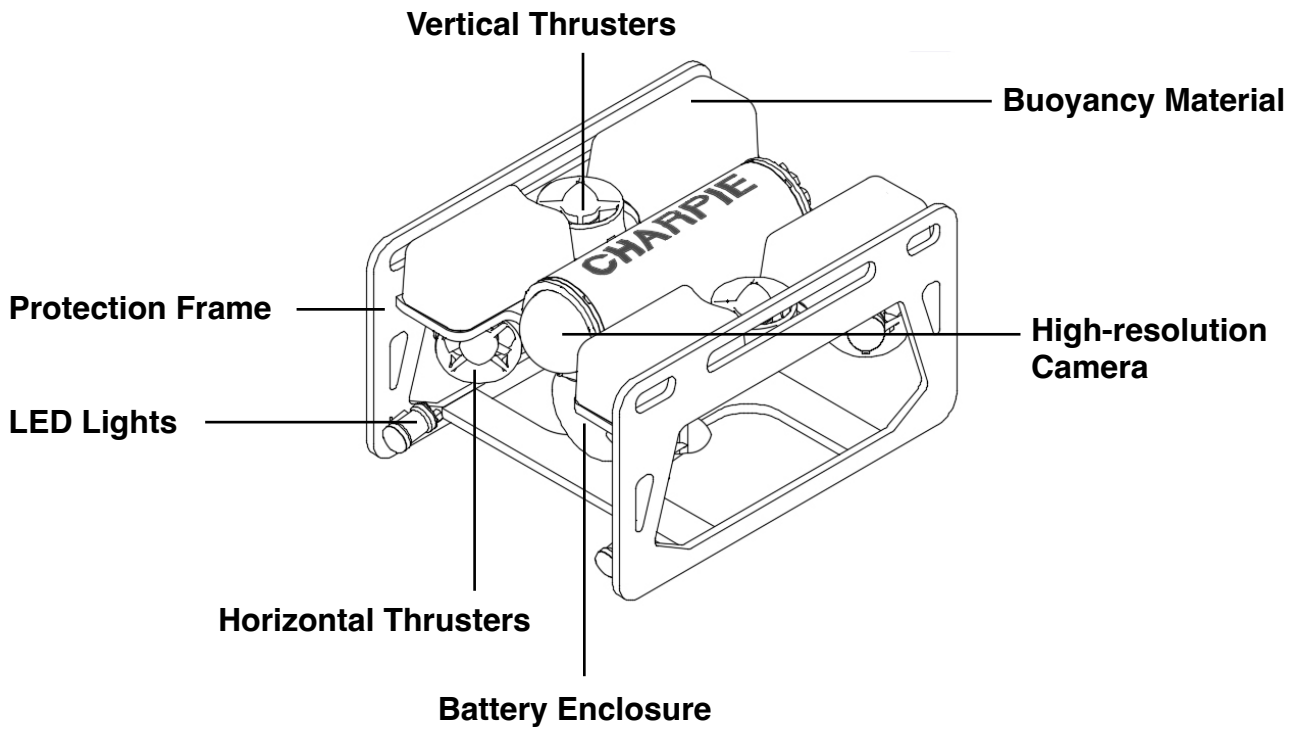

Electronics Enclosure

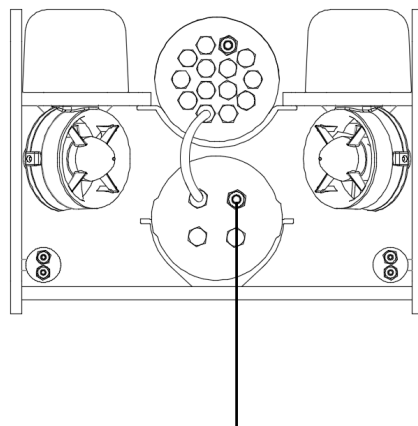

Vent

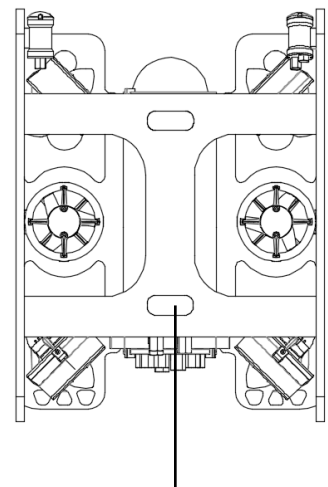

Ballast Block

2. Hardware

2.1 In the Box

1. HX Series ROV x 1
2. Umbilical Cable with Winch x 1
3. Connecting Cable x 2
4. Laptop x 1 (Sold separately)
5. Surface Connector x 1
6. Joystick Controller x 1
7. Spare Propeller x one pair
8. Battery x 1
9. 4-Piece Hex Key Set x one set
10. Balance Charger x 1
11. Spare Sealing O-ring x one set
12. Spare Ballast x 1

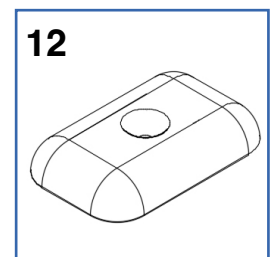
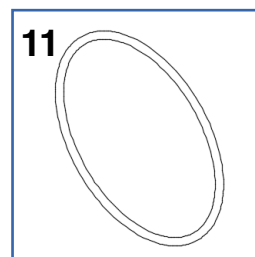
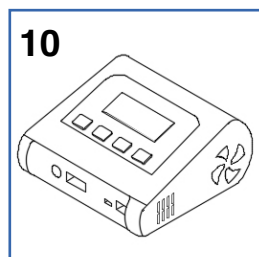
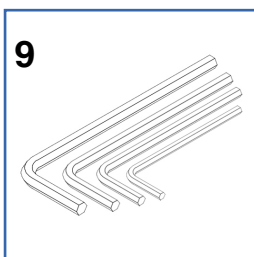
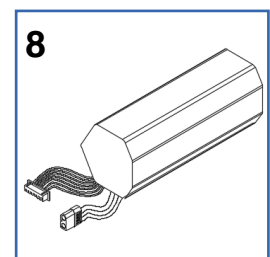
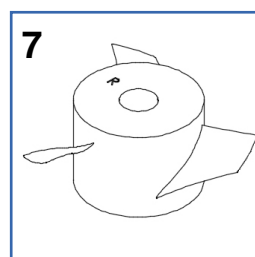
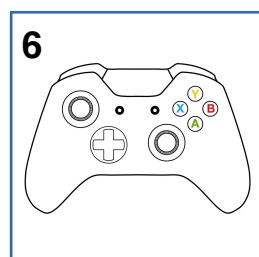
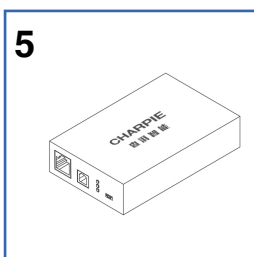
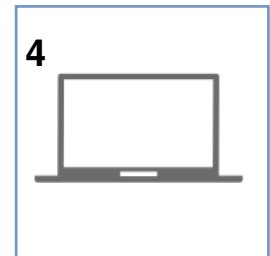
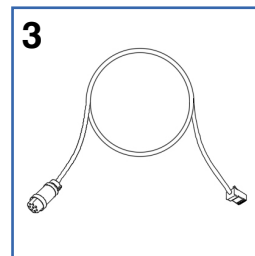
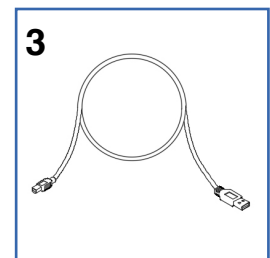
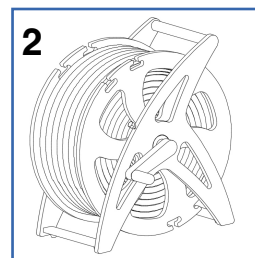
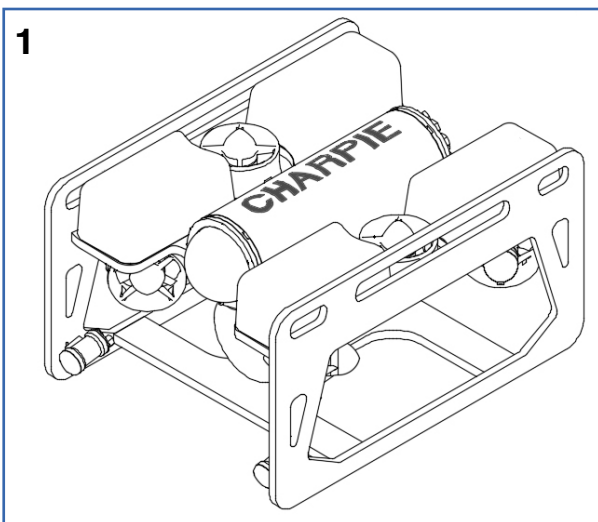

2.2 System Connection

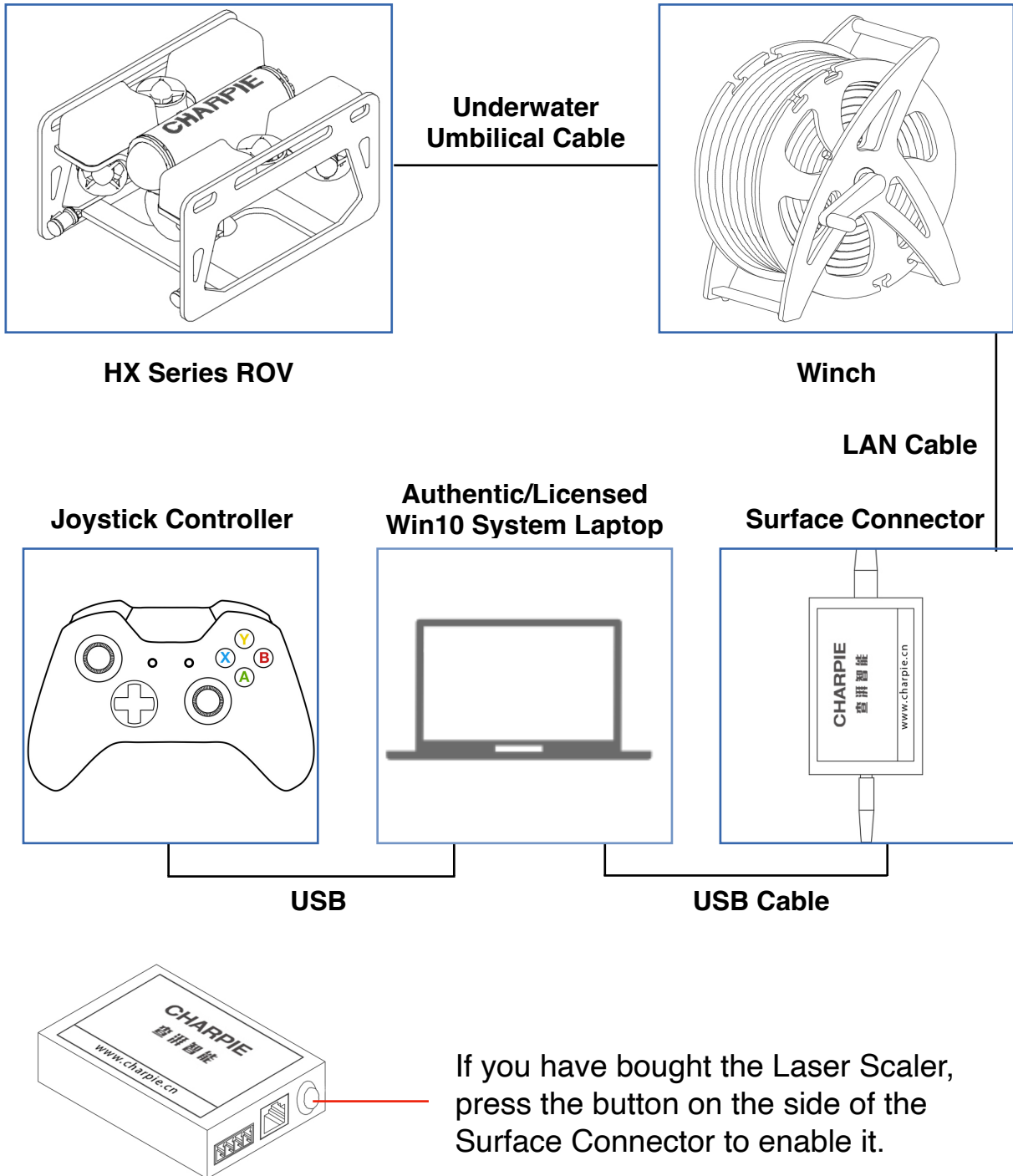

- The Surface Connector is powered by the laptop via usb by default. We suggest you to provide an external independent power supply (e.g. Mobile Power Device) if you will work with LASER SCALER or PIPE-PROFILER.

2.3 Battery Installation

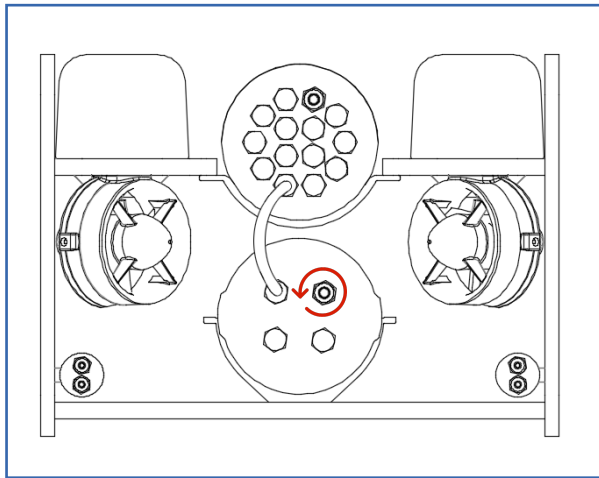

1. Open the battery enclosure vent plug counter-clockwise.

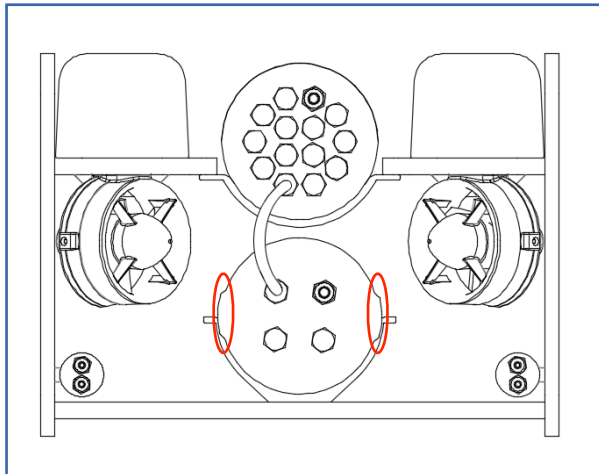

2. Hands on the bumps, pull out the battery cap.

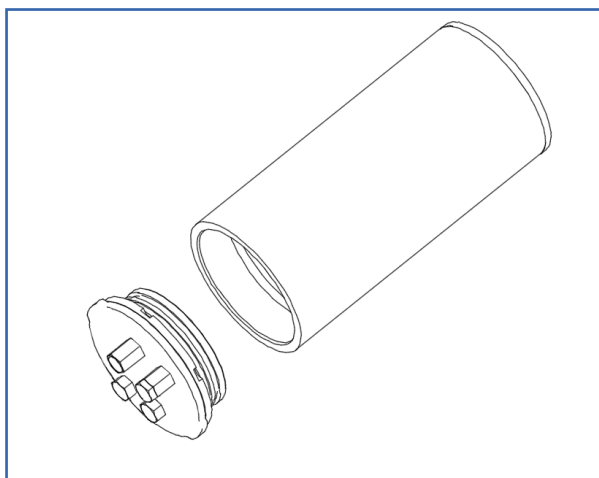

3. Open the battery enclosure.

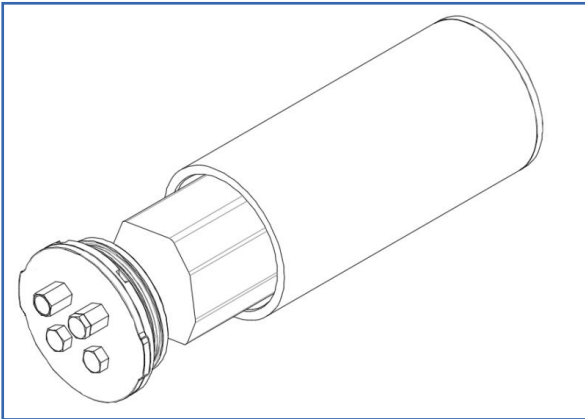

4. Power the ROV by battery.

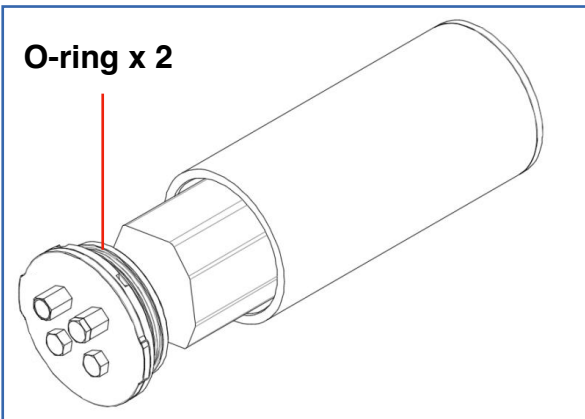

5. Close the battery enclosure and make sure sealing O-rings were tightened properly.

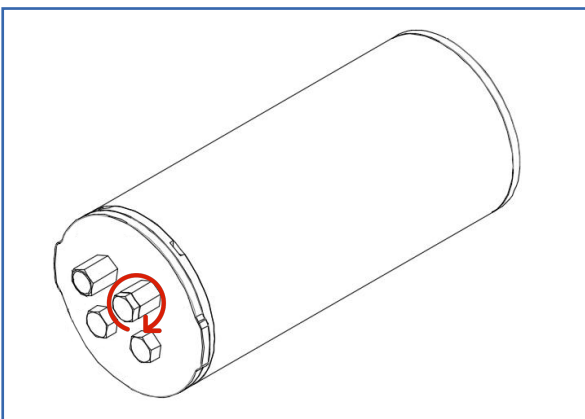

6. Push the plug into vent then tight the plug clockwise.

2.4 Battery Charge

2.4.1 Charger Introduction

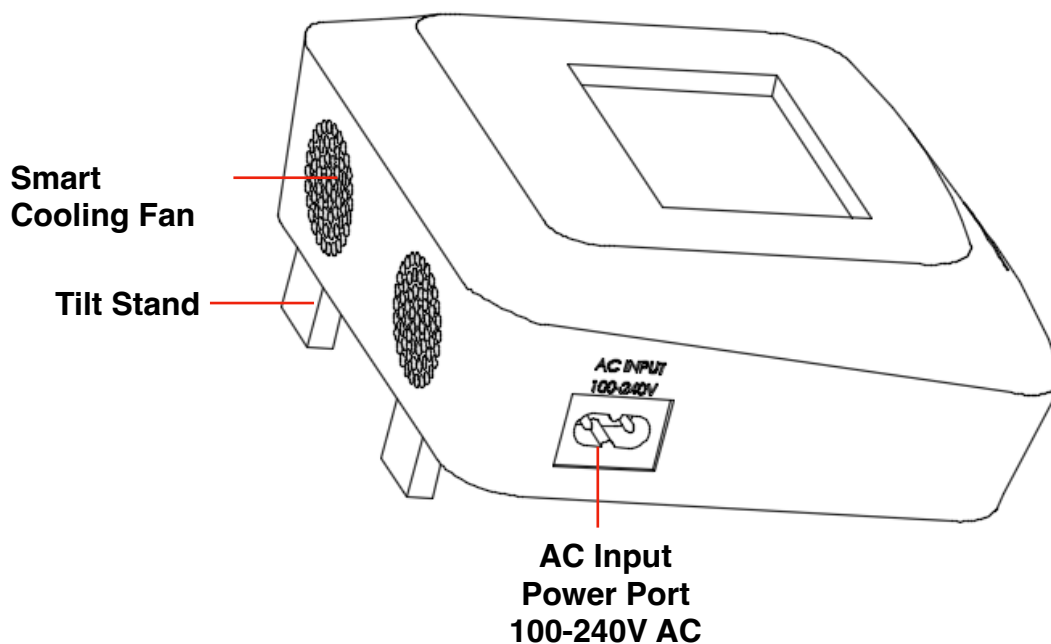
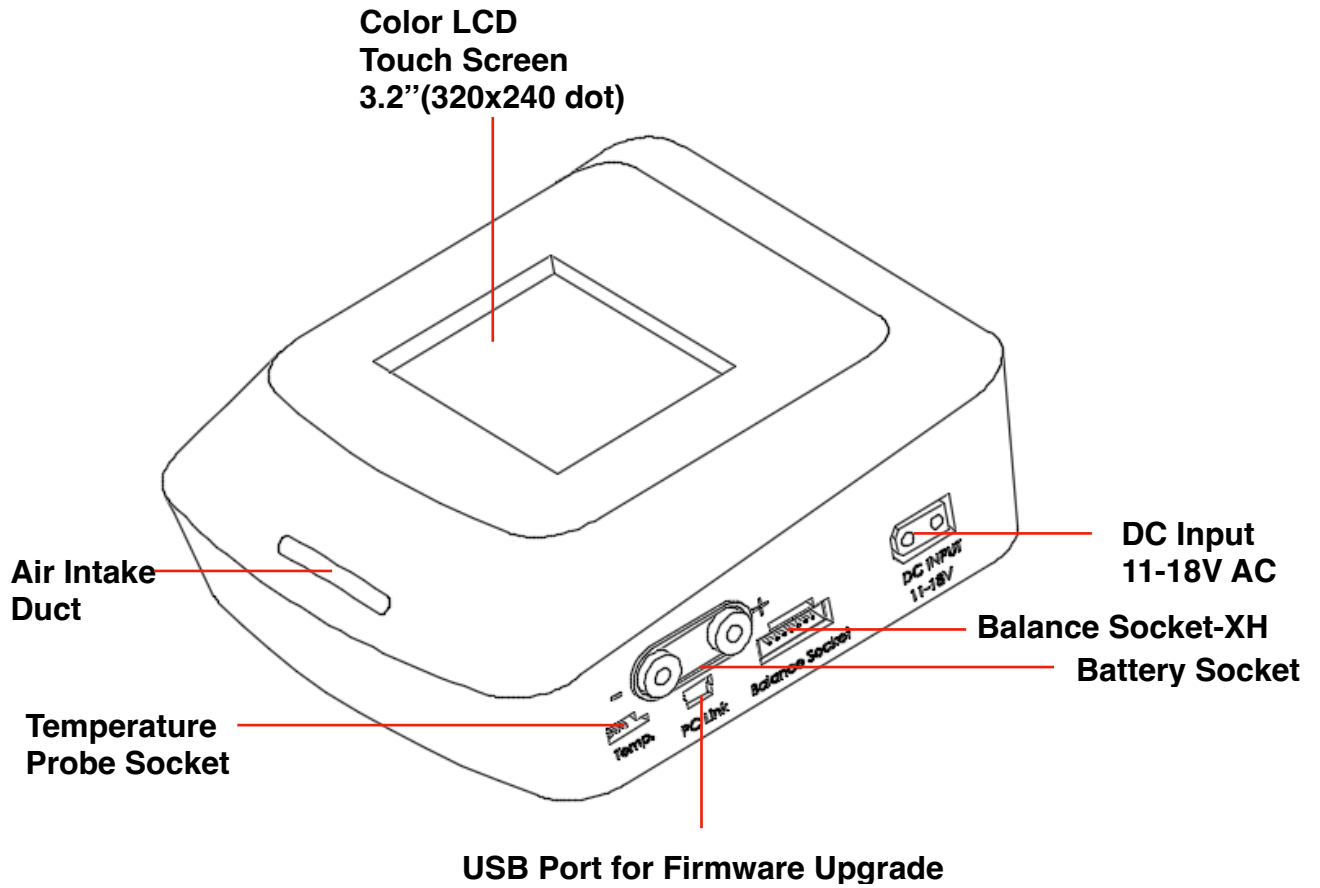

2.4.2 Connection

The balance wire attached to the battery must be connected to the charger with the black wire aligned with negative making. Take care to maintain correct polarity!
(See the wiring diagram below.)

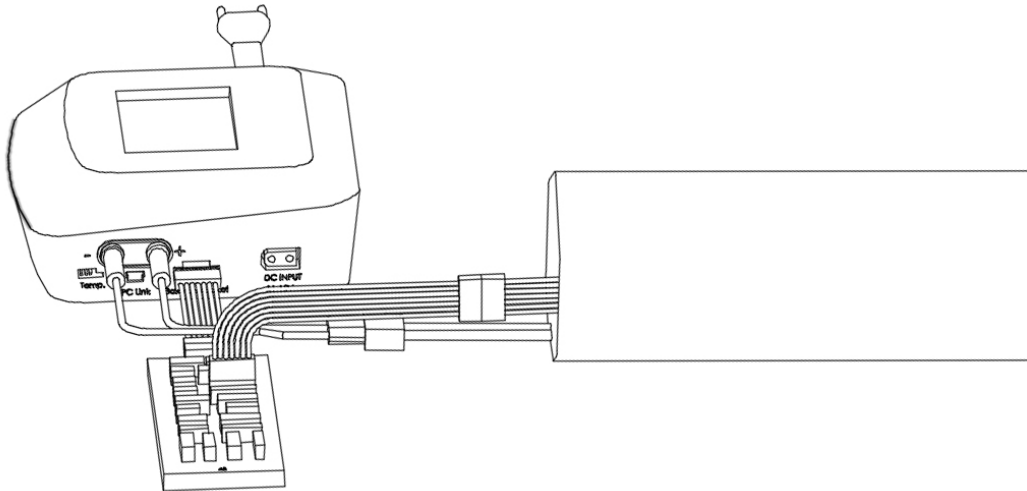

2.4.3 Charge Interface

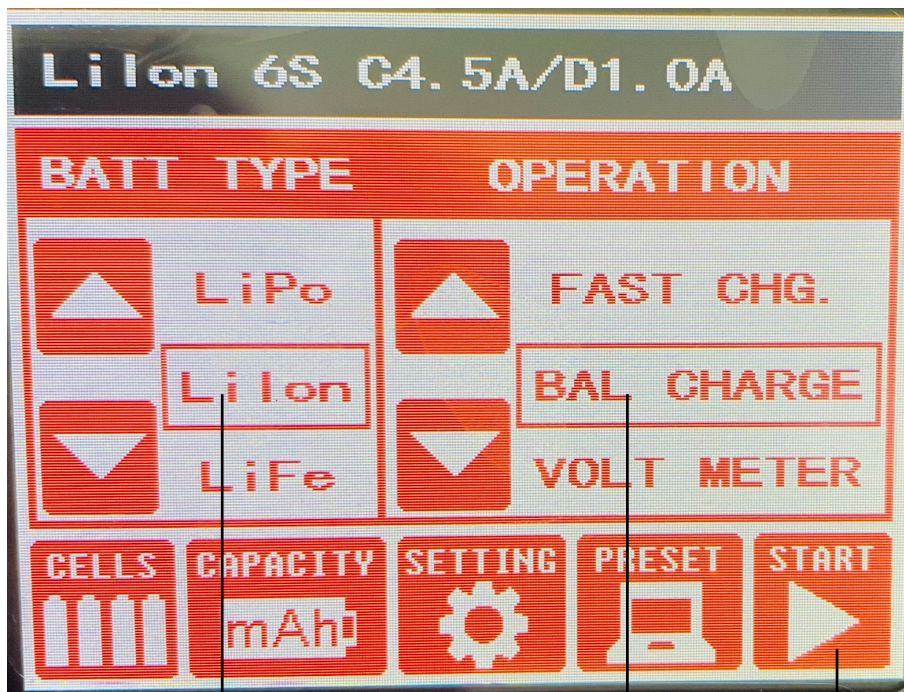

- ① Choose "Li Ion" for battery type.
- ② Choose "BAL CHARGE".
- ③ Press "START" to charge the battery.

3. Software

3.1 Software Installation

 • Skip this step if you have purchased a pre-configured laptop.

1. Download and Unzip the 'Charpie GC' file, run the 'Charpie GC.exe'.



2. In the pop-up window choose both 'Private networks' and 'Public networks' then click 'Allow access', wait until the software shows up.

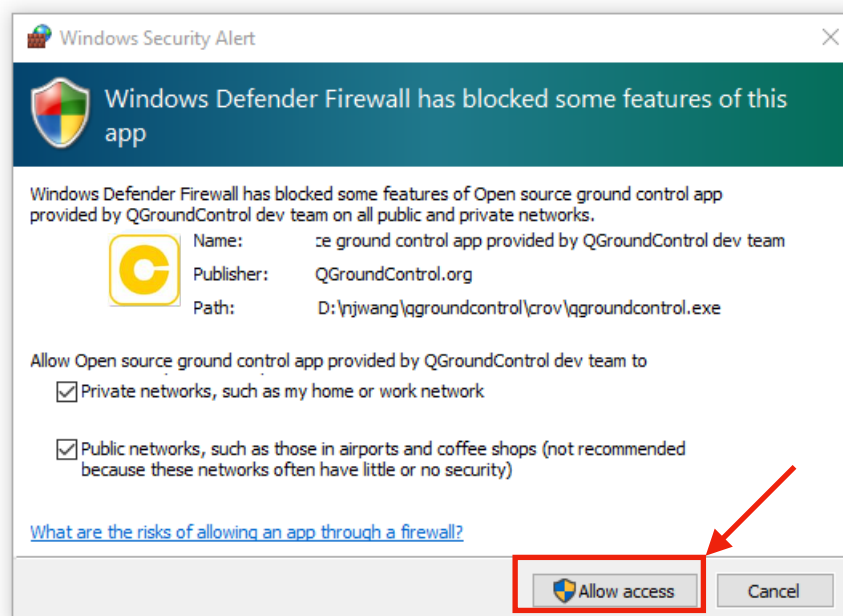

3. Close the Charpie GC software.

4. Copy the 'QGroundControl.ini' file to the 'C:\Users\your name\AppData\Roaming\QGroundControl.org\' folder, and choose 'Replace'.



- 'your name' needs to be modified according to your personal username.

5. Plug the line to the Surface Connector, right-click the network, open 'Network and internet settings', click 'Change adapter options', right-click 'Ethernet', select 'Properties', double-click 'Internet protocol version 4 (TCP / IPv4)', set the IP address to 192.168.2.1.

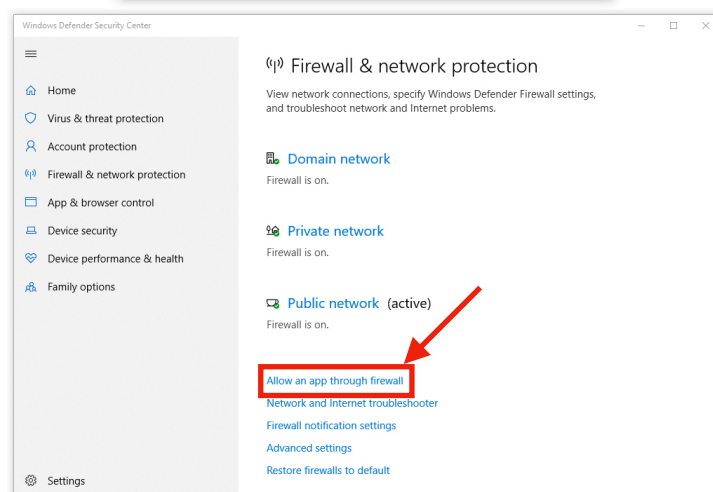
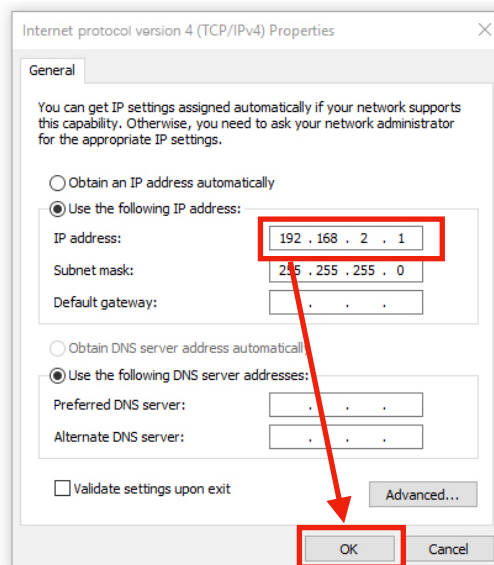

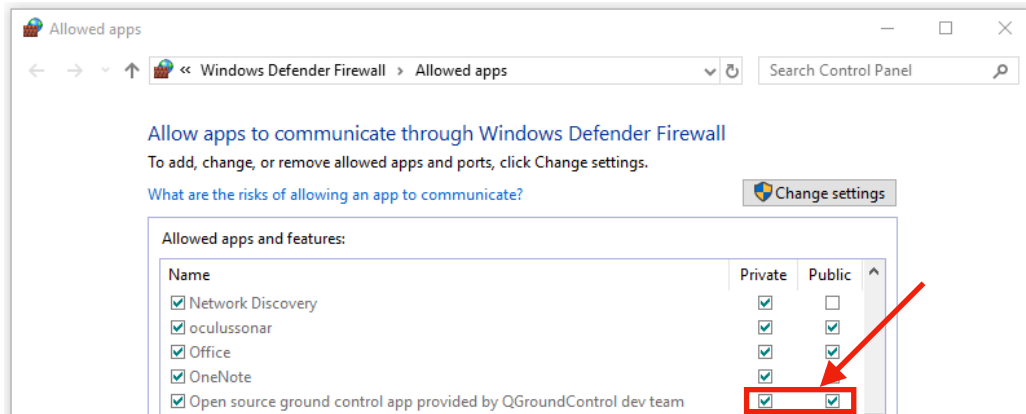

3.2 User Interface

The screenshot shows the CHARPIE ROV user interface. At the top left, there is a 'Return to Home Page' button. The main control area is labeled 'Control Mode (Manual / Depth Hold / Stabilize)'. On the right side, there are buttons for 'Software Settings', 'ROV Settings', and 'Arm/Disarm'. A 'Real-time Voltage' display shows '24.30v'. A status bar at the top of the main window displays: 'Depth: 0.1m Pilot Gain: 10% Current: 2.00A Water Temp: 16°C Cabin Temp: 28°C Time: 11:21:33 Date: 10/03/2020'. The main display area shows an underwater video stream. In the bottom left corner, there are two circular gauges: 'Attitude' and 'Compass'. A red video camera icon is labeled 'Record Video Stream'. A large red box highlights the status bar area, with a label 'Depth, Pilot Gain, Current, Water Temp Cabin Temp, Time, Date' pointing to it.

3.3 Joystick Controller Calibration

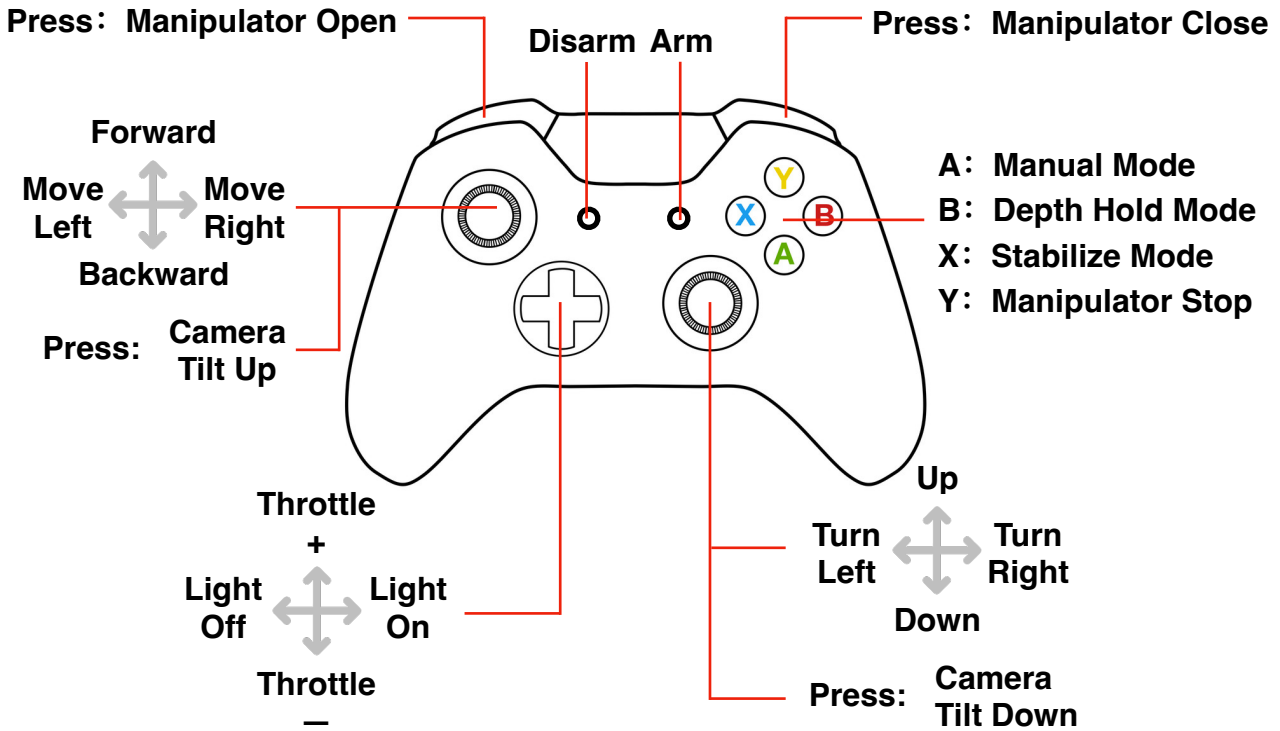

• Skip this step if you have purchased a pre-configured laptop.

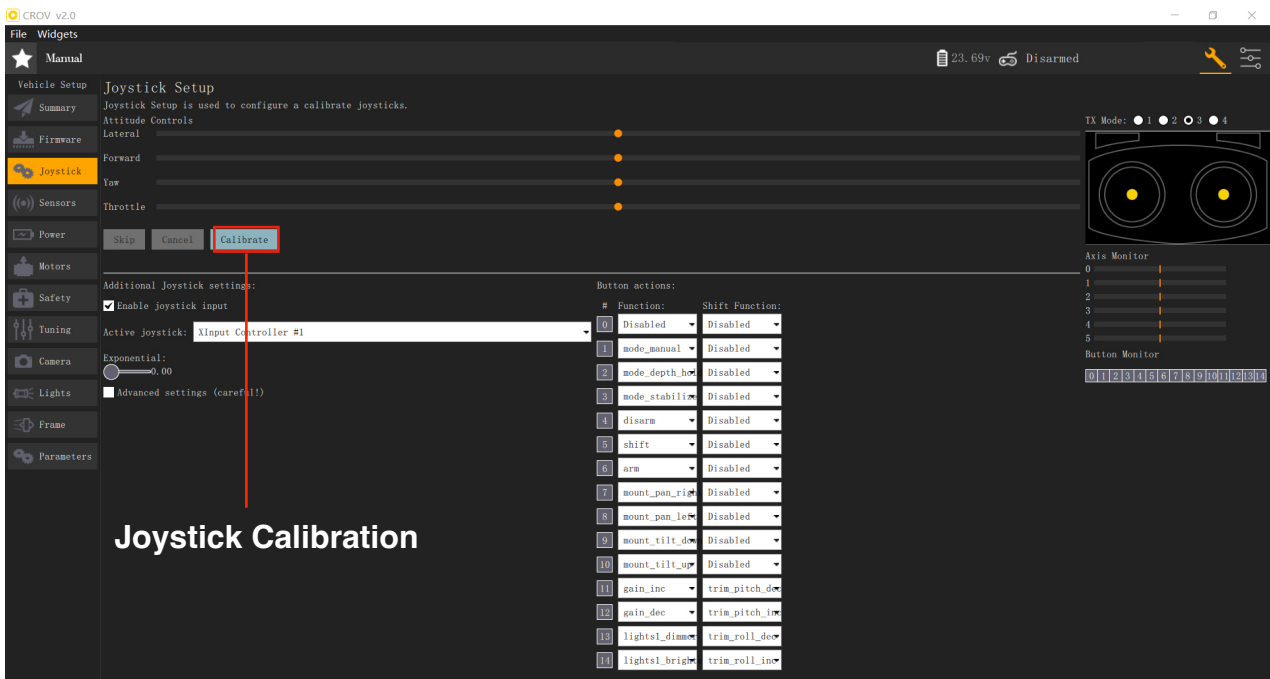

3.4 Sensor Calibration

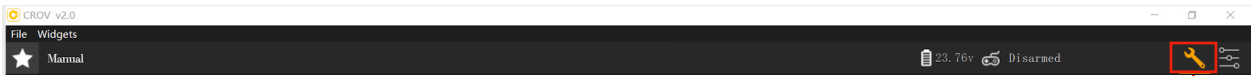

Click to enter the sensor calibration page.

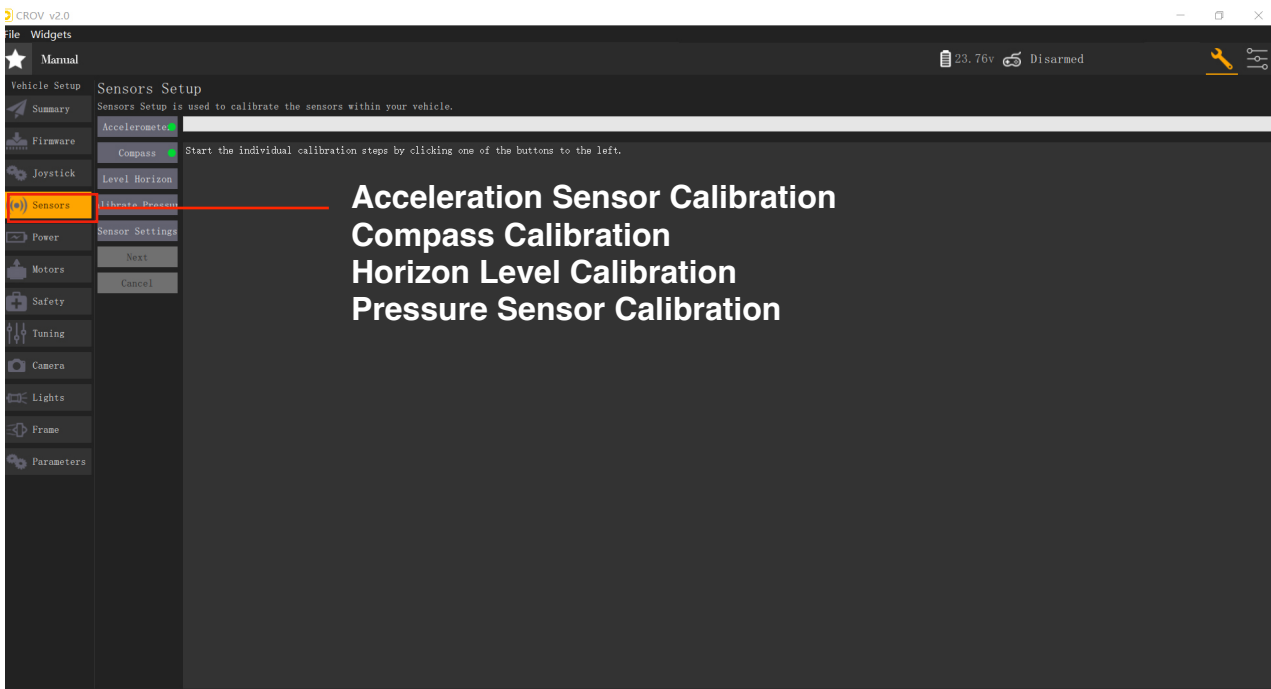

-
- ! • **DO NOT** change other settings if is unnecessary.
 - If you have any question please contact our technical staff.
-

4. Functionality Confirmation

4.1 Desktop Test



- **DO NOT** let the thrusters run consecutively for more than 5s.
 - **DO NOT** let the LED lights turned on consecutively for more than 10s.
 - **ONLY** use Manual mode during desktop tests, or motors will be damaged.
-

1. Open screen recording software (Bandicam by default), choose full screen recording.
2. Open the CROV software wait until the connection between PC & ROV is through and stable.
3. Video display is fluent.
4. Thrusters rotate accordingly with joystick controller (forward/backward, up/down, etc.).
5. The camera gimbal returns to neutral after startup.
6. All lights can be turned on and adjust brightness correctly.
7. The air vent has been tightened.
8. All screws are tightened.
9. Cable outer jacket is intact.

4.2 Underwater Test

- ⚠ • **Leaks may happen if vent is not wholly tightened.**
 - **All loose screws MUST be tightened, ROV may be lost otherwise.**
 - **Operating with broken umbilical cable is FORBIDDEN, leaks or even loss of ROV may happen.**
 - **DO NOT use ROV when water speed is more than 2 m/s.**
 - **Disarm the ROV and retrieve it immediately if required.**
-

1. Unroll a couple meters of cable before diving and as needed throughout the dive.
2. ROV is neutrally buoyant in fresh water and slightly positive in salty water.
3. Video stream is fluent with low latency. No mosaic on image.
4. Try up/down, forward/backward with the joystick controller. Check for smooth movement.
5. Test for speed up/slow down. Check for correct pilot gain reading.
6. Test Depth Hold/Stabilize mode.
7. Take a note on the current heading for destination.

5. Maintenance

5.1 Recovery and Cleaning

1. Switch to Manual mode.
2. Turn off the LED lights and retrieve the ROV back to surface.
3. Open the battery cabin and disconnect the battery with dry hands.
4. Tidy up the thrusters if any debris stuck inside.
5. Rinse the ROV with fresh running water, including the thrusters and tether. Dry up the ROV with clean cloth.
6. Disconnect the cable from the winch and surface control unit.
7. Straighten up the tether on the reel.
8. Keep the battery in dry and safe place after fully recharge.

5.2 Battery Maintenance

1. Maximum operating current is designed as 30A for 4S battery pack and 45A for 6S battery pack. Severe damages might occur if current goes higher. The most possible cases are:

- 1) jammed thruster with hair/aquatic plants/trash
- 2) entangled tether
- 3) strong currents or other adverse conditions below the surface

2. Minimum operating voltage is 12V for 4S battery pack and 18V for 6S battery pack. Stop operating, retrieve the ROV when voltage drops close to these values.

-
- !** • **Disconnect the battery from the cabin immediately after each use and make sure fully recharged before next use. Batteries will be damaged if left unattended and unplugged inside the cabin.**
-

3. Please read through the Instruction Manual inside the battery charger box to know how to charge the battery.

4. Feedback communication cables on the battery can only be connected to the corresponding slots of the balance charger otherwise the battery will burn. Do not pull hard on the cable or you might cause a disconnection which also leads to battery damage.

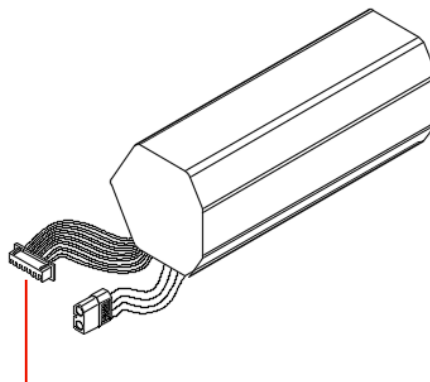

Feedback Communication Cables

6. FAQ

1. 'Waiting for connection' message when the ROV is powered up



Generally it takes several minutes or longer for the connection, so please be patient and wait.

If the connection still failed please check the following items:

- ① The umbilical cable is connected firm and tightened.
- ② The local IP address and firewall settlings on your laptop is correct.
- ③ The normal state of the indicating LEDs on the side of the Surface

Connector is:

Communication Status Indicator Description

Normal	
	— — — Constantly Red
	— — — Yellow Flashes Quickly
	— — — Green Flashes Quickly

2. The thrusters are running out of control when ROV is powered up in the air for desktop test

- ① Change to 'Manual' mode if it is on 'Depth Hold' or 'Stabilize' mode.
- ② Calibrate the joystick controller.
- ③ If all the above attempts tried but still unfixed, disarm the ROV and close the Charlie GC software, contact our tech supporting staff.

3. ROV is not walking straight when asked to

- ① Check if all 6 thrusters are working, especially the horizontal ones. If any of them not working, please power off the ROV and check if any debris or trash stuck inside the motor.
- ② Check the directions of all 4 horizontal thrusters when going forward. If any of them is running the other direction, change the motor direction setting under the guidance of our technical staff.

4. Abnormal depth reading on the UI

Re-calibrate the depth sensor in air.

5. Only video streams without parameter readings

Double click on the video to show the readings.

6. Over-Current

This normally happens in strong water currents, stalled motors or entangled tether. Unlock the control joystick immediately, close the CROV and retrieve the ROV back to the surface for a closer check.

7. Interrupting videos or Mosaic image

Most likely caused by entangled tether or over turnings of the tether. Straighten up the tether as much as possible for better video stream.

7. Service and Tutorial

7.1 After-sale Service

1. Free remote video tutorial session within 1 month since purchased.
2. Maintenance services free of labor costs within one year since purchased.
3. Free annual ROV diagnosis.
4. Send you description with videos & images to support@charpie.cn if anything further.
5. Call for emergencies: +86-21-5881-0772.

Shanghai office hours: Mon - Fri 8: 00-20: 00 (UTC: +8).

-
- ⚠ • **Machine failure caused by improper operations, unauthorised modification, and adverse application environment is NOT covered by the Warranty.**
-

7.2 Online Tutorial

1. YouTube channel with basic operation guides and daily maintenance tips.
2. Linkedin & Facebook updates on company news and new releases.

8. Upgrades and Accessories

For more accessory details, please visit our website www.buyrov.com or call during office hours: +86-21-5881-0772.

Tools	1. Manipulator
	2. Cleaning Brush
	3. Water Sampler
	4. Soil Sampler
	5. Dead Fish Net
	6. Cavitating Jet Cleaning Plate
	7. Underwater Marker & Locator
	8. Underwater Scissor
Structure Detection	1. Laser Scaler
	2. Thickness Gauge
Water Quality	1. PH
	2. Conductivity
	3. Turbidimeter
	4. Dissolved Oxygen
	5. Ammonia - Nitrogen
	6. Blue/Green Algae
Underwater Positioning	1. SBL / USBL
	2. Obstacle Avoidance Sonar
Sonar	1. Mechanical Scanning Sonar
	2. Multi-beam Forward Looking Sonar
	3. Side-scan Sonar
	4. 3D Bathymetry
	5. Fish Finder
	6. Sub-bottom Profiler
	7. Pipe-profiler

CHARPIE

28th Floor, 11 Century Avenue, Shanghai, China
+86-21-5881-0772
sales@charpierov.com

This User Manual is the property of Charpie Intelligent Technology Co., Ltd., and all rights of use are reserved. Contents are subject to change without prior notice. For the latest information, please contact our sales representatives.